

# H77系列碟型止回阀主要尺寸及重量

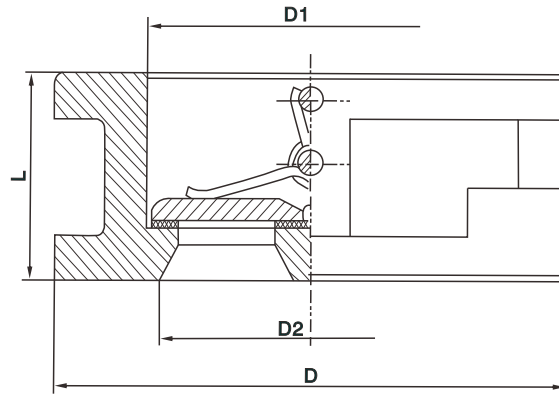

公称压力	公称通径	尺寸				重量	配管法兰(供参考)			
		L	D	D3	D2		螺栓孔中心圆直径D1	螺栓数量	螺栓数量d	螺栓长度L1
PN1.0	40	43	92	55	41	1.8	110	4	M16	105
	50	43	107	65.5	51	2	125	4	M16	150
	65	46	127	81	65	3	145	4	M16	155
	80	64	143	95	80	4	160	8	M16	160
	100	64	162	117.5	102	6	180	8	M16	165
	125	70	192	145.5	127	8	210	8	M16	180
	150	76	218	170.5	152	13	240	8	M20	205
	200	89	273	227.5	203.6	24	295	8	M20	235
	250	114	328	266	254	35	350	12	M20	255
	300	114	380	312	305	48	400	12	M20	290
	350	127	438	362	350	78	460	16	M20	295
	400	140	489	406	400	106	515	16	M24	310
	450	152	539	450	450	135	565	20	M24	325
	500	152	594	505	500	165	620	20	M24	345
PN1.6	40	43	92	55	41	1.8	110	4	M16	105
	50	43	107	65.5	51	2	125	4	M16	150
	65	46	127	81	65	3	145	4	M16	155
	80	64	142	95	80	4	160	8	M16	160
	100	64	162	117.5	102	6	180	8	M16	165
	125	70	192	145.5	127	8	210	8	M16	180
	150	76	218	170.5	152	13	240	8	M20	205
	200	89	273	227.5	203	24	295	12	M20	235
	250	114	330	266	254	37	355	12	M24	265
	300	114	385	312	305	50	410	12	M24	305
	320	127	445	361	350	80	470	16	M24	310
	400	140	495	406	400	110	525	16	M27	330
	450	152	555	450	450	145	585	20	M27	345
	500	152	615	505	500	180	650	20	M30	370
600	178	730	624	600	280	770	20	M33	380	